

PHY2054 Summer 2018 Exam 2 Review Questions

Prof. Douglas H. Laurence

Department of Physical Sciences, Broward College

Chapter 21: Electric Current and Direct Current Circuits

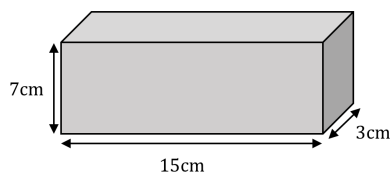

1. Wires could be attached at any two opposite faces on the above conductor. Which attachment would produce the greatest current for any given voltage?
 - (a) Front and back faces
 - (b) Left and right faces
 - (c) Top and bottom faces
 - (d) All would produce the same current

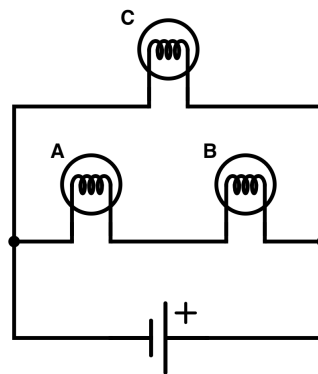

2. In the above figure, each lightbulb has the same resistance. Which lightbulb will glow the brightest?
 - (a) A
 - (b) B
 - (c) C
 - (d) They would glow equally bright in each arrangement

3. Which arrangement of four equal resistors shown above would have the greatest resistance?
- (a) All in series
 - (b) All in parallel
 - (c) A mixture of series and parallel
 - (d) Can't be answered without an arrangement specified

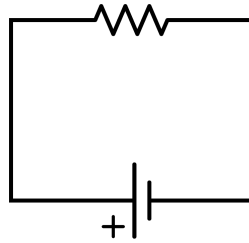

4. Which of the following statements is true of the above circuit?
- (a) The current and the flow of electrons are clockwise
 - (b) The current is clockwise but the flow of electrons is counterclockwise
 - (c) The current is counterclockwise but the flow of electrons is clockwise
 - (d) The current and the flow of electrons are counterclockwise

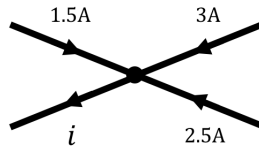

5. What is the value of i in the above figure?
- (a) 1A
 - (b) 2A
 - (c) 4A
 - (d) 7A

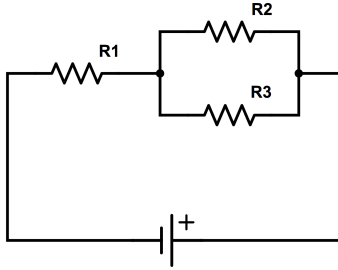

6. For the circuit above, $R_1 = 2\Omega$, $R_2 = 3\Omega$, $R_3 = 1\Omega$, and the voltage of the battery is 5V.
- What is the equivalent resistance of the circuit?
 - How much current produced by the battery?
 - What current flows through R_1 ? In what direction?
 - What is the voltage across R_2 ?

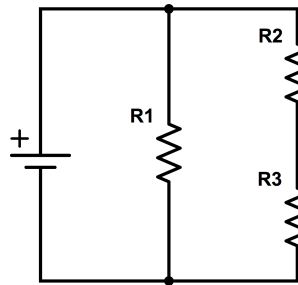

7. For the circuit above, $R_1 = 4\Omega$, $R_2 = 1.5\Omega$, $R_3 = 3\Omega$, and the voltage of the battery is 2V. What is the current through R_1 ?

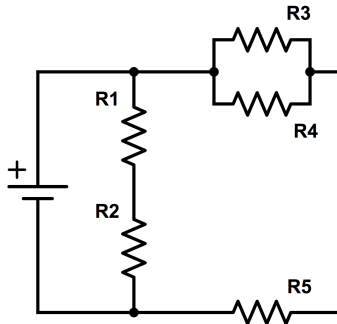

8. For the circuit above, $R_1 = 1\Omega$, $R_2 = 2\Omega$, $R_3 = 1\Omega$, $R_4 = 3\Omega$, $R_5 = 2\Omega$, and the voltage of the battery is 10V.
- What is the equivalent resistance of the circuit?
 - How much current produced by the battery?
 - What current flows through R_3 ?
 - What is the voltage across R_5 ?

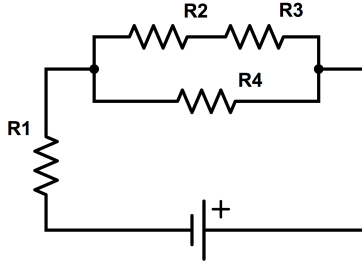

9. For the circuit above, $R_1 = 4\Omega$, $R_2 = 1.5\Omega$, $R_3 = 2.5\Omega$, $R_4 = 4\Omega$, and the voltage of the battery is 8V.
- What is the power output of R_1 ?
 - How much heat is released by R_4 in 5s?
 - What is the total power emitted by all resistors combined?

Chapter 22: Magnetism

- A wire carries a current into the page. In what direction does the magnetic field produced by the wire point?
 - Away from the wire
 - Towards the wire
 - Clockwise around the wire
 - Counterclockwise around the wire
- A wire running East-West carries a current to the east while the Earth's magnetic field points to the North. In what direction does the wire feel a magnetic force?
 - West
 - North
 - Up
 - Down
- A 5C charge moving with a speed of 15 m/s upward enters a 2T magnetic field into the page, causing it to undergo circular motion. After one-quarter of a revolution, how much work is done on the charge?
 - 0J
 - 50J
 - 100J
 - 150J

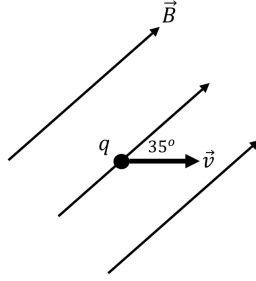

4. A charge $q = -9 \text{ nC}$ moves with a speed of $v = 10,000 \text{ m/s}$ in the presence of a magnetic field $B = 0.05 \text{ T}$, as shown in the figure above. What is the force, both magnitude and direction, on the charge?
- (a) $2.6 \mu\text{N}$, into the page
 - (b) $2.6 \mu\text{N}$, out of the page
 - (c) $4.5 \mu\text{N}$, into the page
 - (d) $4.5 \mu\text{N}$, out of the page

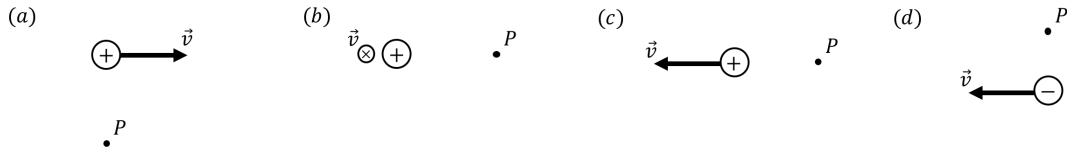

5. For each of the above situations, (a) through (d), indicate the direction of the magnetic field produced at P by the moving charge. If no magnetic field is produced, indicate $B = 0$.
6. Two very long, parallel wires separated by a distance of 15 cm carry currents in opposite directions. If one wire carries a current of 150 A and the other carries a current of 200 A , what is the magnitude of the magnetic field halfway between the wires?
7. Consider the same wires in the previous problem. What is the force that each wire exerts on the other? Is the force attractive or repulsive?

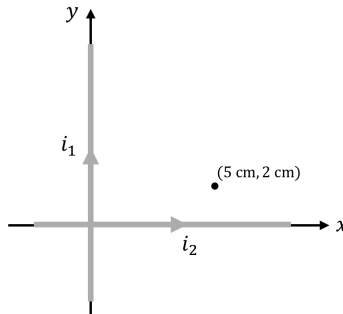

8. Two very long wires carry the currents $i_1 = 3000 \text{ A}$ and $i_2 = 2000 \text{ A}$ as shown in the figure above. What is the magnetic field, both magnitude and direction, at the point indicated in the figure?

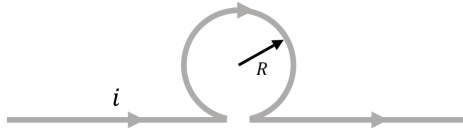

9. What is the magnetic field at the center of the loop in the above figure if $i = 750$ A and $R = 20\text{cm}$?
10. A solenoid with 100 turns per cm is placed on top of a table, oriented so that it would produce a magnetic field to the East, with a compass placed just at the edge of the solenoid. If the Earth's magnetic field runs to the North and has a strength of $B_E = 10^{-4}$ T, what current must run through the solenoid so that the compass' needle points exact halfway between North and East?

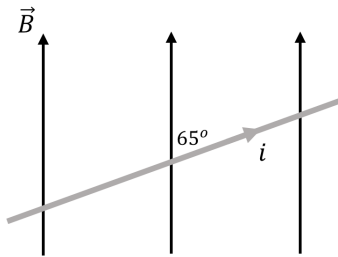

11. A very long wire carrying a current $i = 400$ A passes through a vertical magnetic field $B = 0.1\text{T}$ as shown in the above figure. What is the **force per unit length**, F/L , acting on the wire? In what direction does this force act?

Chapter 23: Magnetic Flux and Faraday's Law of Induction

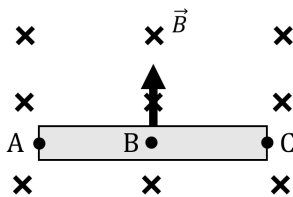

1. Which point on the conductor above is the point of high potential?
 - (a) A
 - (b) B
 - (c) C
 - (d) All points are at the same potential

2. A coil is moved in and out of a region with a uniform magnetic field, without changing its orientation, inducing a current in the coil. What is changing that induces a current in the coil?
- (a) The strength of the magnetic field
 - (b) The area that magnetic field lines pass through
 - (c) The angle between the coil and the magnetic field
 - (d) None of the above

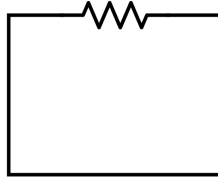

3. Imagine a magnetic field passed through the center of the above circuit, into the page. If that magnetic field were increasing, what direction would the induced current flow through the resistor?
- (a) Left
 - (b) Right
 - (c) No current would be induced in the circuit
 - (d) More information needs to be given

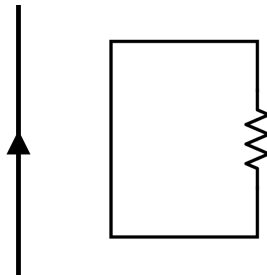

4. A very long wire carries a current upward next to a conducting loop, as shown in the figure above. If the current in the wire increases, in what direction does the induced current flow through the loop?
- (a) Clockwise
 - (b) Counterclockwise
 - (c) No induced current will be produced
 - (d) More information needs to be given

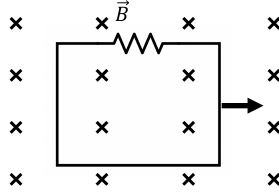

5. A conducting loop moves through a uniform magnetic field as shown in the above figure. In what direction does the induced current flow in the loop?
- Clockwise
 - Counterclockwise
 - No induced current will be produced
 - More information needs to be given

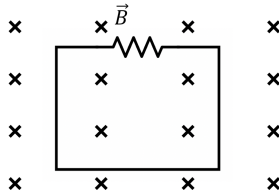

6. A square, $15\text{cm} \times 15\text{cm}$ loop is immersed in a uniform magnetic field \vec{B} , as shown above.
- If $B = 0.5\text{ T}$, how much magnetic flux passes through the loop?
 - If the magnetic field increases at 0.01 T/s , what is the induced EMF in the circuit?
 - If the resistor was 10Ω , what would the induced current be?
 - In what direction would the induced current flow through the resistor?

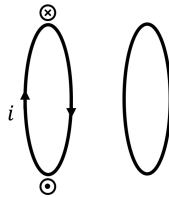

7. Two conducting loops, each with a radius of 10cm , are placed very close to one another. The left loop carries a current i that flows into the page at the top of the loop and out of the page at the bottom, as shown in the figure above.
- If the current in the left loop increases at 0.5 A/s , how quickly is the magnetic field produced by the loop changing?
 - How quickly is the magnetic flux through the right loop changing? *Only consider the magnetic field produced at the center of the left loop in this calculation.*
 - What is the induced current in the right loop if it has a resistance of 5Ω ?
 - What is the direction of the current in the right loop? Give your answer in terms of into/out of the page at the top of the loop.

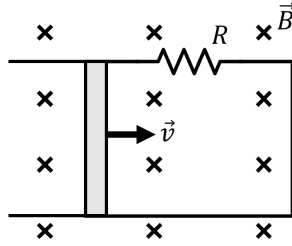

8. A conductor of length 4cm moves to the right at 150m/s in the presence of a uniform 0.01T magnetic field, as shown in the figure above. The conductor slides along wires connected to a resistor with $R = 15\Omega$.

- (a) Why is there an induced current in this circuit?
- (b) What is the magnitude of the induced EMF in this circuit?
- (c) What is the magnitude of the induced current through the resistor?
- (d) In what direction does the current flow through the resistor?